

COLORSCAPE 90 MULTI LIGHT SYSTEM

INSTALLATION GUIDE



COLOR KINETICS INCORPORATED
10 MILK STREET, SUITE 1100
BOSTON, MA 02108
TEL 888 FULL RGB
TEL 617 423 9999
FAX 617 423 9998
POOLANDSPA@COLORKINETICS.COM
HTTP://POOLANDSPA.COLORKINETICS.COM

ColorScape 90 Multi Light System
ITEM# 115-000006-00

U.S. PATENTS 6,016,038 AND 6,150,774
OTHER PATENTS PENDING

©2001-2002 Color Kinetics Incorporated. All rights reserved. Chromacore, Color Kinetics, the Color Kinetics logo, ColorBlast, ColorPlay, iColor, iPlayer, and Smartjuice are registered trademarks, and ColorScape, iColor Cove, and QuickPlay are trademarks of Color Kinetics Incorporated.

All other brand or product names are trademarks or registered trademarks of their respective owners.

PUB-000057-01 Rev 00

Specifications subject to change without notice.



GETTING STARTED

Congratulations on your purchase of a Color Kinetics® ColorScape™ Multi Light System. Welcome to a more colorful world brought to you by Color Kinetics and Chromacore®, our patented technology that generates colored light and effects using a microprocessor to control red, green and blue LEDs.

This guide contains important information on installing and using your new ColorScape system. Please read it carefully and save it for future reference. There are very few rules, but those that exist are there for your safety.

Included In This Box

- (1) ColorScape 90 Light with face ring and 50 feet of cable
- (1) 3-Button Control Box
- (4) Zip ties
- (2) Niche mounting screws: M5x45mm, flat-head phillip; 10-24x1.75" flat-head slotted
- Installation Guide

Additional Items Needed

- Pre-installed pool light niche - fiberglass, vinyl, or concrete/gunite (one per light)
- 3/4" and 1" Schedule 40 PVC conduit
- All purpose cement (suitable for use with PVC, ABS, styrene and CPVC pipe and fittings)
- (4) #10 pan-head wood or sheet metal screws
- Three-conductor 18 AWG supply cord

Optional Items

- ColorScape 90 Multi Light System Extension (required for three- and four-light systems)
- Additional ColorScape 90 Lights (up to four lights total)

INSTALLING COLORSCAPE

WARNING: The ColorScape Light Fixtures, Control Box, and System Extension should be installed by a qualified electrician in accordance with NEC and relevant local codes. See the "Safety Precautions" section of this guide for more information.

INSTALLATION CONSIDERATIONS

Before installing the underwater lights, consider the following:

- The ColorScape 90 is designed to be installed, completely submerged into a vertical wall.
- Install the lights in a direction facing away from the home or living areas near the pool.
- The fixture must be installed in a wall of the pool with the top of the lens opening not less than 4 inches (102mm) below the normal water level of the pool.

Installing the Light Fixtures

The ColorScape 90 light easily installs into a standard, pre-installed, swimming pool niche.

- Feed the six-wire electrical cord through the niche, into the conduit, and up to the location of the control box. **DO NOT CUT EXCESS CORD.** The excess cord allows you to raise the fixture to the pool deck for maintenance and light angle adjustments.
- Coil the extra electrical cord into the niche and place the light into the niche with the screw opening at the top (12:00) position.
- Ensure the clip is seated in the notch at the bottom of the niche, then attach the mounting screw at the top of the face ring.
- When removing the light from the niche, remove the mounting screw at the top of the light and lift light up and out of the niche.

Fig. 1

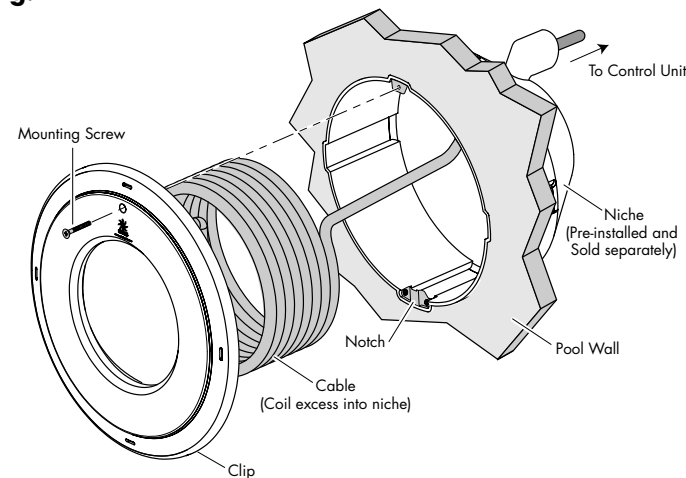

Adjusting the Light Angle

To reduce glare, the ColorScape 90 Light allows for adjustment of the light angle to 4° below horizontal.

WARNING: Ensure the power is off before removing and adjusting fixtures. Otherwise, damage to the fixture may result.

1. Remove the mounting screw from the face ring, remove the light from the niche, then raise it to the pool deck.
2. Using a phillips screwdriver, remove the two backplate screws. (See Fig. 2.)
3. Separate face ring from the light by pressing the retaining clip.
4. Rotate the face ring 180°.

5. Reattach the face ring, in the new position, by fastening the retainer clip and replacing the two backplate screws.
6. Insert the light into the niche as described in the previous section, *Installing the Light Fixture*.

The light is now angled at 4° below horizontal.

Fig. 2

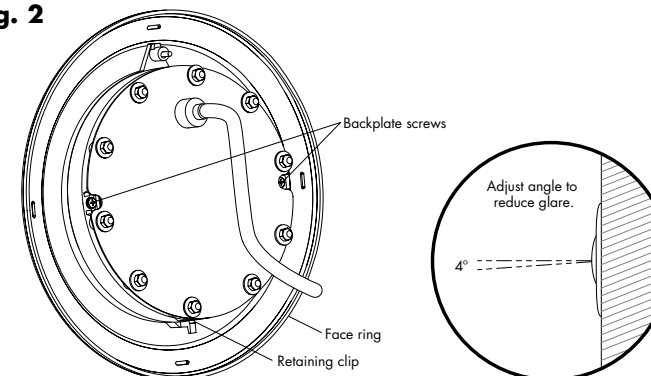

Wiring ColorScape 90 Lights

The ColorScape 90 Control Box supports two ColorScape 90 Lights. Adding the optional System Extension box, expands the ColorScape 90 system to supports up to four lights.

NOTE: When your system includes multiple lights, it is important to install the lights in a sequentially numbered order. The numbered order determines how colors move from light to light and affects the appearance of the light show.

WARNING: Ensure the power is off before connecting or disconnecting fixtures. Otherwise, damage to the fixture may result.

Each ColorScape 90 light comes with 50 feet of cable. In selecting an installation location, make sure there is enough cable to reach between the pool and the control box. After selecting a suitable location for the control box, run conduits for the lights and power to the site.

Fig. 3

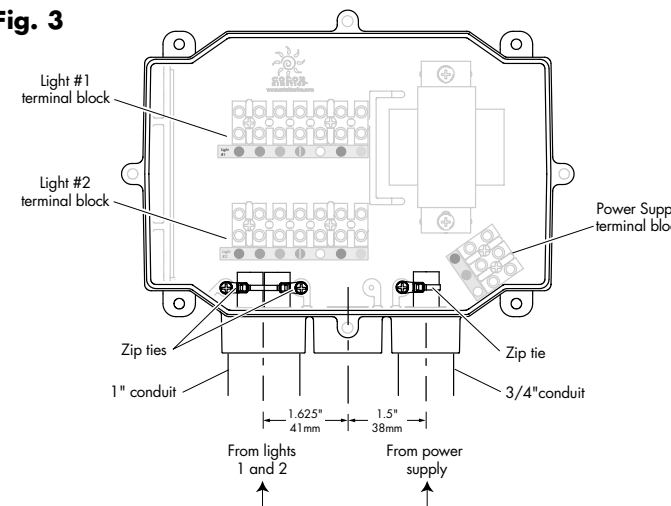

1. Using a phillips screwdriver, remove the four cover screws and lift off the control box cover.
2. Feed the incoming power supply cable from the 3/4-inch conduit through the right knockout into the control box.
3. Connect the incoming power supply cable to the terminal block, matching the wire colors to the terminals, as shown in Fig. 4.
4. Feed the light cables from the 1-inch conduit through the left knockout into the control box.

5. Connect Light 1 to the terminal block labeled Light #1. Match the wire colors to the terminals as shown in Fig. 4.
6. Repeat Step 5 for Light 2, if applicable.
7. Attach the zip ties to the cables to provide strain relief, as shown in Fig. 3.

Fig. 4

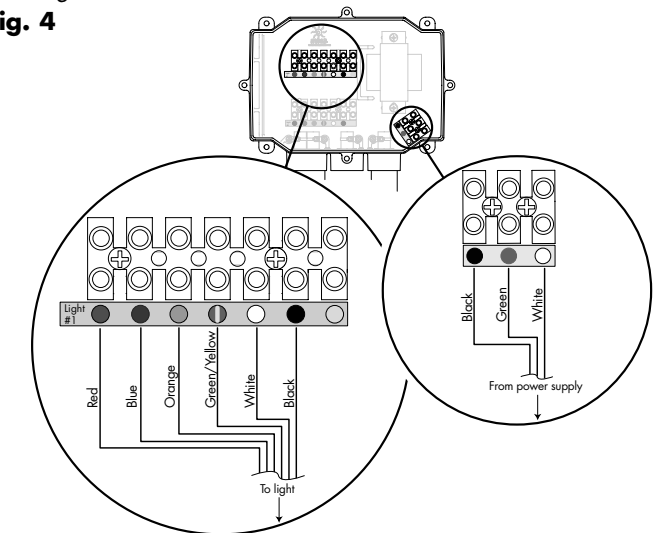

Wiring Additional ColorScape Lights

Three- and four-light systems require the ColorScape 90 System Extension Box. For details on wiring lights 3 and 4, refer to the *ColorScape 90 System Extension Box Installation Guide*.

Installing the control box

WARNING: Ensure the power is off before mounting the control box. Otherwise, serious personal injury and/or major property damage may result.

Fig. 5

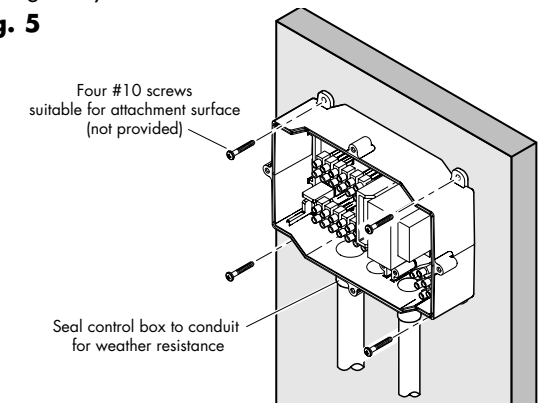

MOUNTING THE CONTROL BOX

Once you have wired the lights and power supply, and secured the cables for strain relief, you are ready to mount the control box.

- Slide the control box onto the top of the conduit. Following the directions with your sealant cement, ensure that the conduit is sealed to the control box.
- Mount the control box to a flat surface using four wood or sheet metal screws. (Screws not included)
- Replace the control box cover using the four cover screws, using caution not to over-torque screws.

Installation is complete. You are now ready to begin enjoying your ColorScape90 System.

WARNING: Do not clean the control box with abrasives or solvents. Use soap and water when necessary.

USING COLORSCAPE 90

The ColorScape 90 Multi Light System includes six built-in lighting effects. The three-button control box lets you choose the lighting effect you want: use the left button to choose an effect, then use the center button to select options within that effect. Use the right button to adjust the brightness.

EFFECT 1: CHASING RAINBOW

Chasing Rainbow uses multiple fixtures to produce rainbow of light. The Chasing Rainbow effect cycles smoothly through the spectrum of colors, and gives the appearance that the colors move from light to light.

Chasing Rainbow options:

- 1: Fast
- 2: Medium
- 3: Slow

EFFECT 2: FIXED COLOR

Fixed Color is a static display of one of eight possible colors.

Fixed Color options:

- 1: White
- 2: Pink
- 3: Lavender
- 4: Light Blue
- 5: Dark Blue
- 6: Light Green
- 7: Dark Green
- 8: Peach

EFFECT 3: COLOR WASH

Color Wash cycles smoothly through the spectrum of colors.

Color Wash options:

- 1: Fast: 5 seconds
- 2: Medium: 15 seconds
- 3: Slow: 30 seconds

EFFECT 4: RANDOM COLOR

Random Color produces a randomly generated sequence of colors.

Random color options:

- 1: Fast: .25 of a second
- 2: Medium: 1 second
- 3: Slow: 3 seconds

EFFECT 5: CARIBBEAN GREEN-BLUE CHASING CROSS FADE

Caribbean Green-Blue Chasing Cross Fade cycles smoothly from green to blue and back, and gives the appearance that the colors follow each other from light to light.

Caribbean Green-Blue Chasing Cross Fade options:

- 1: Fast: 5 seconds
- 2: Medium: 15 seconds
- 3: Slow: 30 seconds

EFFECT 6: SUNSET RED-YELLOW CHASING CROSS FADE

Sunset Red-Yellow Chasing Cross Fade cycles smoothly from red to yellow and back, and gives the appearance that the colors follow each other from light to light.

Sunset Red-Yellow Chasing Cross Fade options:

- 1: Fast: 5 seconds
- 2: Medium: 15 seconds
- 3: Slow: 30 seconds

CONTROL BOX SPECIFICATIONS

- POWER INPUT**
- 120 VAC
- POWER OUTPUT**
- 2.0A @12 VAC (24W)
- POWER SUPPLY**
- 120 – 12V transformer
- DIMENSIONS**
- 10.25" X 7.0" X 3.38"
- CONNECTORS**
- Euro style screw terminal blocks

LIGHT SPECIFICATIONS

SOURCE LIFE

Color Kinetics illumination products utilize high brightness LEDs as the illumination source. LED manufacturers predict LED life of up to 100,000 hours MTBF (mean time between failure), the standard used by conventional lamp manufacturers to measure source life. However, like all basic light sources, LEDs also experience lumen depreciation over time. So while LEDs can emit light for an extremely long period of time, MTBF is not the only consideration in determining useful life. LED lumen depreciation is affected by numerous environmental conditions such as ambient temperature, humidity and ventilation. Lumen depreciation is also affected by means of control, thermal management, current levels, and a host of other electrical design considerations.

Color Kinetics systems are expertly engineered to optimize LED life when used under normal operating conditions [ambient temperature: -4° F to 104° F (-20° C to 40° C), humidity: 0-95% non-condensing humidity, adequate ventilation and air volume] and when operated using typical color-changing effects. Long-term operation outside of these ranges or conditions, or at the upper limits of these ranges or conditions, may subject the product to further degradation of the LED source life, or in extreme cases, failure of internal components. Source life information is based on LED manufacturers' data, as well as other third party testing.

- COLOR RANGE**
- Numerous colors available
- SOURCE**
- High brightness colored LEDs
- CONNECTORS**
- Flying leads
- TEMP RANGE**
- -4°F to 113°F (-20°C to 45°C)
- CONTROL**
- Water-resistant three-button control box
- POWER REQUIREMENT**
- 1A @ 12 VAC
- POWER CONSUMPTION**
- 12W per light

SAFETY PRECAUTIONS

WARNING Do not operate this fixture for more than ten minutes unless it is totally submerged in water.

INSTALLATION RESTRICTIONS

Underwater lighting fixtures and fixture housings must be installed by a qualified electrician and under the provisions of article 680 of the NEC and relevant local codes.

The following guidelines must be followed:

- The installing electrician should verify that the pool meets the requirements of the current National Electrical Code and all local codes and ordinances.
- The lighting circuit must have a Ground Fault Interrupter (GFCI) and an appropriately rated circuit breaker.
- The junction box or control box must be located at least 8 inches above the maximum water level of the pool and at least 48 inches from the edge of the pool.
- The niche has an approved combination bond-grounding connector that allows internal connection of a No. 8 AWG copper conductor where rigid non-metallic conduit of a plastic niche is used in accordance with article 680-20 of the National Electrical Code (NEC). The integral external connection is for connecting the bond wire required by the NEC article 680-22.

If any problems occur during usage, disconnect power to the product immediately and contact:

Color Kinetics Technical Support Group:
1-888-FULL RGB or 617-423-9999 or
support@colorkinetics.com